

NEWS





TABLE OF CONTENTS



04
PLIXY
Franco Poli



06
SEVEN
Ciani Design



08
LAYER
Franco Poli



10
OYSTER
Franco Poli



12
CROSS
Massimo Colombo



14
JAPAN WOOD
Franco Poli



18
JAPAN STEEL
Franco Poli



22
GRID
Ciani Design



26
LUIGI FILIPPO
Marta Laudani e Marco Romanelli



32
LAYER
Franco Poli



34
MEDIOLANUM
Studio Ideazione



36
LUX
Edoardo Radice



38
NEANDERTHAL
Franco Poli

01

PLIXY

Franco Poli



Veloce, sottile eppure forte, PlixY è snella come un tratto di penna. Progettata per sparire con discrezione, si apre rapidamente quando serve una seduta dove il design è stile e sostanza: la struttura in acciaio inox gioca con il calore delle doghe in faggio laccato, disponibili in vari colori.

Rapid, slim but strong, PlixY is as slender as the stroke of a pen. Designed to discreetly disappear, it can be quickly opened when a chair is needed combining style and substance: the stainless steel structure contrasts with the warmth of the lacquered beech slats, available in various colours.



02

SEVEN

Ciani Design

La modernità in una sedia. Linea pulitissima, stile netto, grande personalità nello spazio anche nel minimalismo del segno. Seven accoglie con forme ampie, ancora più confortevoli nella versione con rivestimento in tessuto. La struttura è in acciaio trafilato o in tubo, con particolare verniciatura opaca e goffrata, in vari colori.

Modernity in a chair. Extremely sleek lines, a clear-cut style, and a large personality in its space, even in its minimalism. Seven is inviting with ample forms, which are even more comfortable in the version with fabric upholstery. The frame is in drawn or tubular steel, with a special matt and embossed lacquered finish in various colors.



03

LAYER

Franco Poli



Continuità avvolgente di due singole superfici che si connettono in una preziosa cucitura ribattuta enfatizzando l'eleganza del rivestimento in un design ergonomico e sinuoso: lo stile di Layer risiede in questa morbidezza confortevole che, pur occupando poco spazio, è perfetta per arredare con garbo un ufficio direzionale, un'area conversazione oppure un elegante salottino.

The enveloping continuity of two individual surfaces that connect in an exquisite riveted seam, emphasising the elegance of upholstery in an ergonomic, sinuous design: the style of Layer lies in this comfortable softness that, while taking up little space, is perfect for furnishing an executive office, conversation area or an elegant living room with grace.



04

OYSTER

Franco Poli



Una poltroncina a pozzetto che invita ad accomodarsi e prendersi una pausa. Autorevole e moderna nel design, Oyster si inserisce con forte personalità in qualsiasi contesto, grazie anche allo stile pulito e ai colori decisi. Un'unica forma che accoglie e sostiene, perfetta per spazi attesa e direzionali.

A bucket chair that invites you to sit down and take a break. With its strong personality and modern design, Oyster blends in with any surroundings, due also to its simple style and bold colours. A simple shape offering comfort and support, ideal for waiting areas and executive offices.



05

CROSS

Massimo Colombo



Con le sue forme accoglienti e distensive questa poltroncina invita a celebrare il lusso della quiete. Progettata per spazi lounge o per un angolo relax e lettura, accoglie nel comfort dell'ampia struttura in metallo, con imbottitura in schiumato di poliuretano espanso, rivestibile in tessuto o pelle e dotata di meccanismo oscillante e alzata a gas.

With its enveloping and relaxing shapes, this armchair invites you to celebrate the luxury of stillness. Designed for lounge areas or a relaxation and reading corner, it is enveloping in the comfort of its large metal frame with polyurethane foam upholstery, which can be covered in fabric or leather, and is equipped with a swing mechanism and gas lift.



06

JAPAN WOOD

Franco Poli

Solidità pulita, linearità moderna, essenzialità di classe: il nome orientale rivela l'ispirazione stilistica di questo tavolo dal design forte e sicuro, proposto con pregiate finiture in legno noce Canaletto o rovere canadese.

Sleek solidity, modern linearity, classy simplicity: the Oriental name reveals the stylistic inspiration behind this table with its strong, confident design, offered in exquisite finishes in Canaletto walnut or Canadian oak.



06

JAPAN WOOD

Franco Poli



06

JAPAN STEEL

Franco Poli

Tra le versioni disponibili, Japan è realizzato anche con piano in legno e gambe in acciaio verniciato opaco, rifinito con un particolare effetto gofrato e proposto in diversi colori.

Among the available versions, Japan is also made with a wooden top and matt lacquered steel legs, finished with a special embossed effect and available in different colours.



06

JAPAN STEEL

Franco Poli



07

GRID

Ciani Design



07

GRID

Ciani Design

Un tavolo che arreda senza timidezza e diventa protagonista forte di un ambiente, portando un carattere intensamente moderno e la vitalità di un disegno dinamico. La base è in acciaio trafilato elettrosaldato, in diversi colori a scelta. Il piano viene proposto con finitura laccata coprente oppure in noce Canaletto o rovere canadese.

It is a table that furnishes without hesitation, and becomes the strong protagonist of an environment by offering its intensely modern character and the vitality of dynamic design. The base is made of electro-welded drawn steel, and is available in a choice of colours. The top is available with an opaque lacquer finish in Canaletto walnut or Canadian oak.

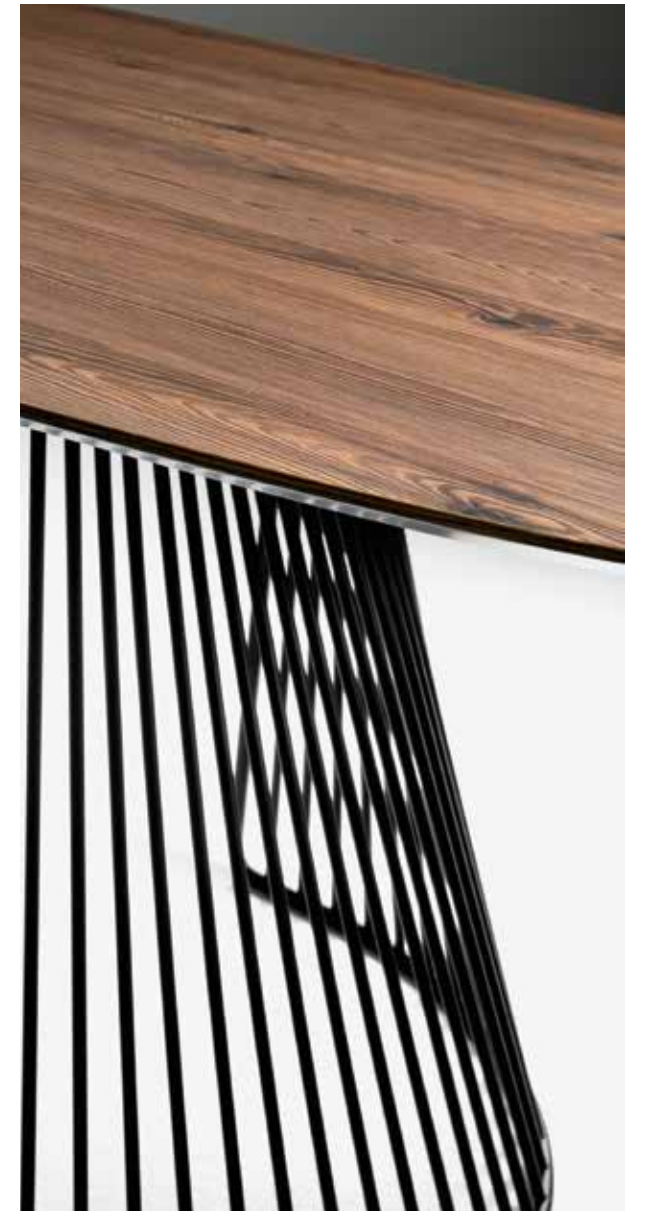

08

LUIGI FILIPPO

Marta Laudani e Marco Romanelli

La forma ovale del classico tavolo in stile diventa potentemente moderna se realizzata con colori energetici oppure abbinando materiali a contrasto, come il legno e il vetro. Da un disegno pulito ed equilibrato nasce un tavolo che sa essere elegante e pratico, da posizionare come elemento distintivo o da vivere ogni giorno in grande libertà.

The oval shape of the classic style table becomes powerfully modern when created with bright colours or the combination of contrasting materials, such as wood and glass. Its sleek and balanced design creates a table that knows how to be both elegant and practical, to be positioned as a distinctive element or experienced every day in full freedom.



08

LUIGI FILIPPO

Marta Laudani e Marco Romanelli

Luigi Filippo viene oggi proposto con i nuovi piani in diverse forme e misure e nelle nuove versioni, scrittoio e consolle.

Luigi Filippo is now being presented with new tops in different shapes and sizes and also in new versions, writing desk and console.



08

LUIGI FILIPPO CONSOLLE

Marta Laudani e Marco Romanelli



LUIGI FILIPPO SCRITTOIO

Marta Laudani e Marco Romanelli



09

LAYER

Franco Poli

Iconico, futuribile, protagonista assoluto dello spazio che arreda con moderna leggerezza. La forte base in MDF accoppiato è laccata in un'affascinante bianco opaco, mentre il prezioso piano in cristallo ovale offre una trasparenza che sembra fluttuare nell'aria. Il design insegna che le scelte più ardite ti conquistano ogni giorno.

Iconic and futuristic, it is the absolute star of the space it furnishes, with modern lightness. The strong base in laminated MDF is lacquered in a fascinating matt white, while the exquisite oval crystal top offers transparency that seems to float in air. Design teaches us that the boldest choices have the power to win hearts every day.



10

MEDIOLANUM

Studio Ideazione

Un'idea di tavolino eclettico che offre tante combinazioni diverse. Solido e leggero allo stesso tempo, si adatta ad esigenze di gusto e di spazio proponendo piani sia rotondo che quadrato, in grandezze diverse, con basi a scelta, colori a catalogo o personalizzabili, sia per interni che per esterni. Insomma, pronto a tutto.

An eclectic coffee table idea that offers many different combinations. Both solid and light, it adapts to the needs of taste and space, offering both round and square tops, in different sizes, with selectable bases and both catalogue or customisable colours, for both indoor and outdoor use. In short, it's ready for anything.

VERSIONE OUTDOOR / OUTDOOR VERSION

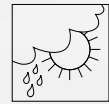

LUX

Edoardo Radice

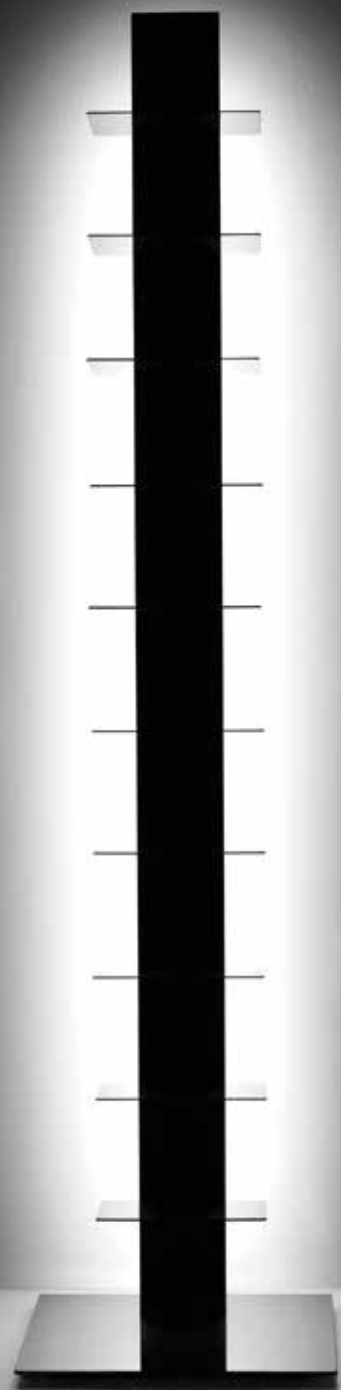

La luce amplifica lo spazio creando punti di valore. Questo moderno corpo illuminante, in alluminio profilato, si può applicare con facilità per creare suggerimenti luminosi in qualsiasi ambiente. È nato per essere abbinato alla libreria Sapiens tramite il semplice utilizzo di magneti e offre una luce a Led dimmerabile, guidandovi alla scoperta del vostro libro preferito.

Light amplifies space, highlighting points of interest. This modern lighting body made of profiled aluminium can be easily applied to create atmosphere in any environment. It is designed to be combined with the Sapiens bookcase via the simple use of magnets, and it features a dimmerable LED light to guide you to your favourite book.



12

NEANDERTHAL

Design: Franco Poli

Una materia dal sapore forte e primario, modellata per contenere i pensieri più evoluti: ecco l'idea di progetto di questa libreria in lamiera d'acciaio, con mensole tagliate a laser. Eclettica, modernissima e colorata, Neanderthal è prodotta in versione con base free-standing o fissa, nelle misure da 9 mensole o più bassa da 5. È prevista anche una versione a sospensione a 5 mensole.

A material with a strong primitive flavour, modelled to contain highly evolved thoughts: this is the design idea of this sheet steel bookcase with laser-cut shelves. Eclectic, ultra-modern and colourful, Neanderthal is produced in a version with a free-standing or fixed base, in sizes with 5 or 9 shelves. There is also a suspended version with 5 shelves.



01 PLIXY

Franco Poli

Sedia pieghevole. Struttura in acciaio verniciato colore nero lucido o finitura acciaio inox effetto mirror.
 Sedile e schienale in doghe di faggio laccato nei colori sotto riportati.

Folding chair. Steel frame painted glossy black, or mirrored stainless steel finish.
 Seat and backrest in coloured lacquered beech slats, in many colors as shown below.

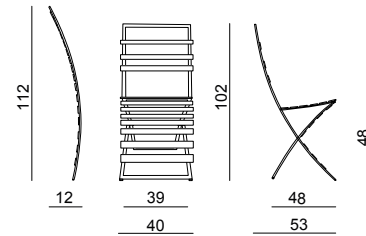

COLORI DOGHE / SLATS COLOURS

Vernici opache e lucide
 Matt varnish and lacquer

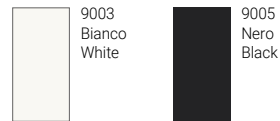

Vernici colorate trasparenti
 Stain colours



Legno placcato
 Plated wood

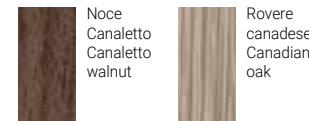

02 SEVEN

Ciani Design

Sedia con sedile e schienale imbottiti e struttura in metallo.
 Disponibile in versione slitta in acciaio trafilato e quattro gambe in metallo.

Verniciatura opaca goffrata nei colori sotto riportati.
 Rivestimento in tessuto o pelle come da cartella rivestimenti BBB.

Chair with upholstered seat and backrest, and metal frame.
 Available in drawn steel sled version and four metal legs.
 Embossed matt lacquer in many colors as shown below.
 Upholstery in fabric or leather as per the BBB upholstery chart.

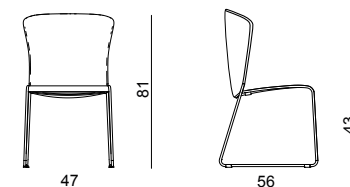
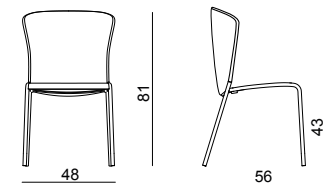

COLORI TELAIO / FRAME COLOURS

Vernici opache
 Matt varnish

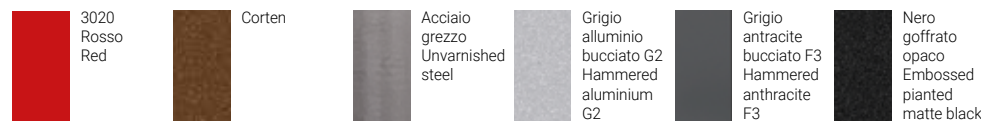

03 LAYER

Franco Poli

Poltroncina con struttura in metallo ed imbottitura in schiumato di poliuretano espanso.
 Rivestimento in tessuto o pelle come da cartella rivestimenti BBB.

Armchair with metal frame and polyurethane foam padding.
 Upholstery in fabric or leather as per the BBB upholstery chart.

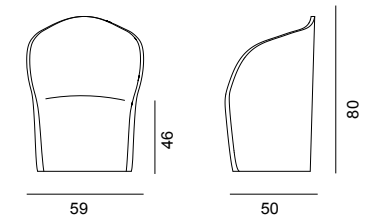

04 OYSTER

Franco Poli

Poltroncina con struttura in metallo ed imbottitura in schiumato di poliuretano espanso.
 Rivestimento in tessuto o pelle come da cartella rivestimenti BBB.

Armchair with metal frame and polyurethane foam padding.
 Upholstery in fabric or leather as per the BBB upholstery chart.

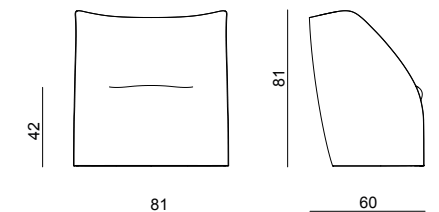

05 CROSS

Massimo Colombo

Poltroncina lounge con struttura in metallo ed imbottitura in schiumato di poliuretano espanso.
 Base a 4 razze in alluminio diametro 700 mm, meccanismo oscillante e alzata a gas.
 Disponibile nella versione con braccioli e senza braccioli.
 Rivestimento in tessuto o pelle come da cartella rivestimenti BBB.

Lounge armchair with metal frame and polyurethane foam padding.
 4-spoke aluminium base diameter of 700 mm, swing mechanism and gas lift.
 Available with and without armrests.
 Upholstery in fabric or leather as per the BBB upholstery chart.

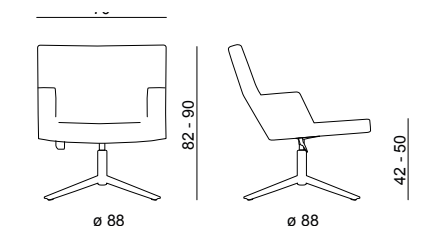
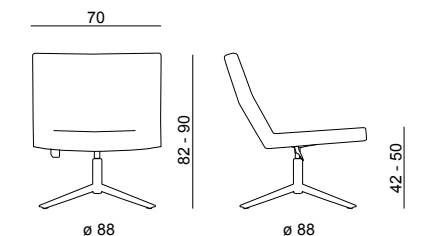

06 JAPAN WOOD

Franco Poli

Tavolo in legno placcato in noce Canaletto o rovere Canadese. Disponibile con piano in legno da 240 e 210 cm.

Plated wooden table in Canaletto walnut or Canadian oak. Available with a 240 and 210 cm wooden top.

COLORI PIANO E STRUTTURA / TOP AND FRAME COLOURS

Legno placcato
Plated wood

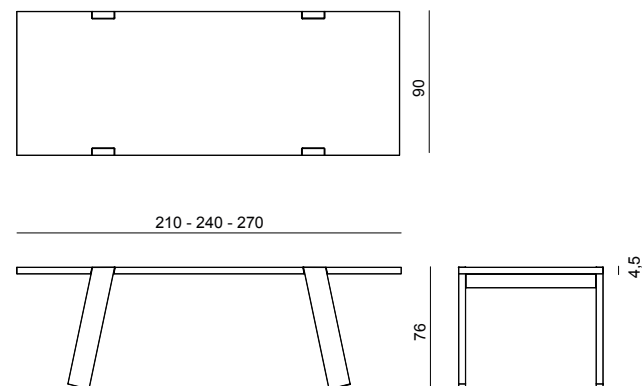
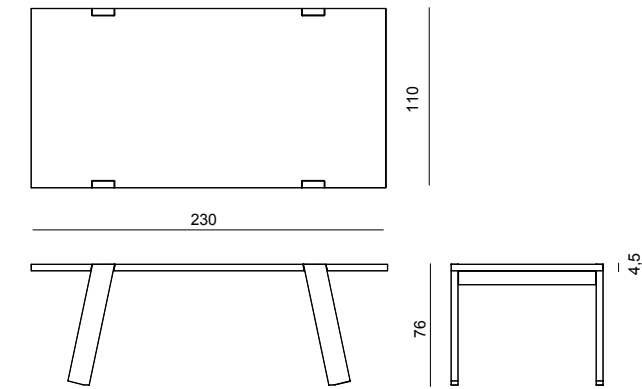
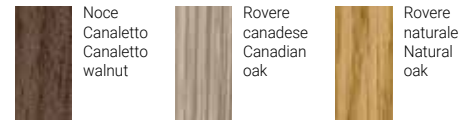

06 JAPAN STEEL

Franco Poli

Tavolo con piano in legno placcato in legno noce Canaletto o rovere Canadese, in abbinamento alla struttura in acciaio verniciato opaco goffrato nei colori sotto riportati. Disponibile nelle misure da 240 e 210 cm.

Table with a plated wooden top in Canaletto walnut or Canadian oak, combined with a matt lacquered steel frame embossed in many colors as shown below. Available in sizes from 240 and 210 cm.

COLORI PIANO / TOP COLOURS

Legno placcato
Plated wood

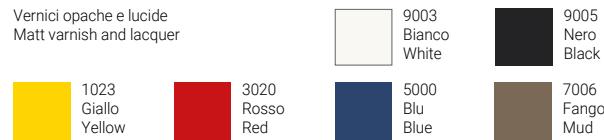
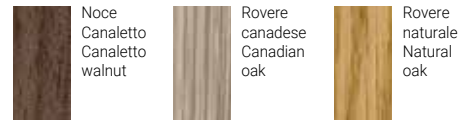

COLORI STRUTTURA / FRAME COLOURS

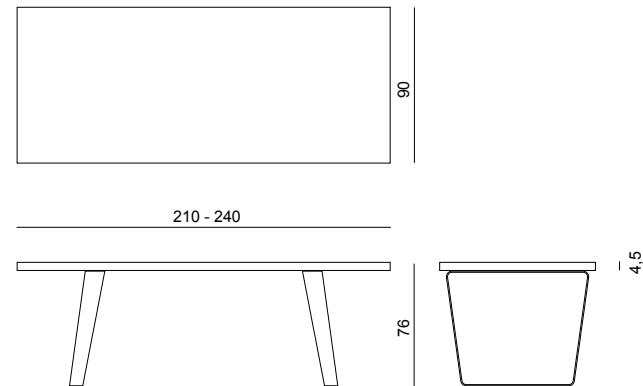
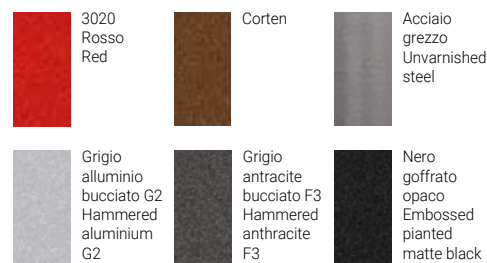

07 GRID

Ciani Design

Tavolo con piano in medium density laccato coprente nei colori sotto riportati, o con piano in legno placcato in noce Canaletto o rovere Canadese, in abbinamento alla struttura in acciaio trafilato ed elettrosaldato, verniciato opaco goffrato nei colori sotto riportati. Disponibile nelle misure da 260, 240 e 210 cm.

Table with an opaque lacquered medium density top in many colors as shown below, or with a wooden top lacquered in Canaletto walnut or Canadian oak, paired with a drawn and electro-welded steel frame, matt lacquered and embossed in many colors as shown below. Available in sizes from 260, 240 and 210 cm.

COLORI PIANO / TOP COLOURS

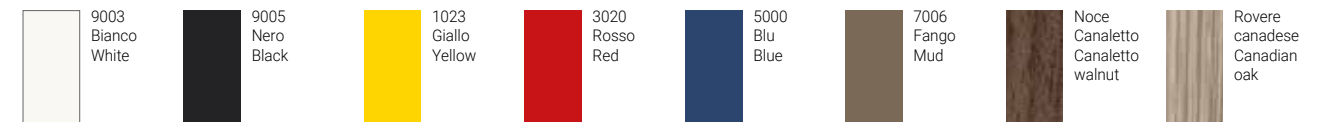

COLORI STRUTTURA / FRAME COLOURS

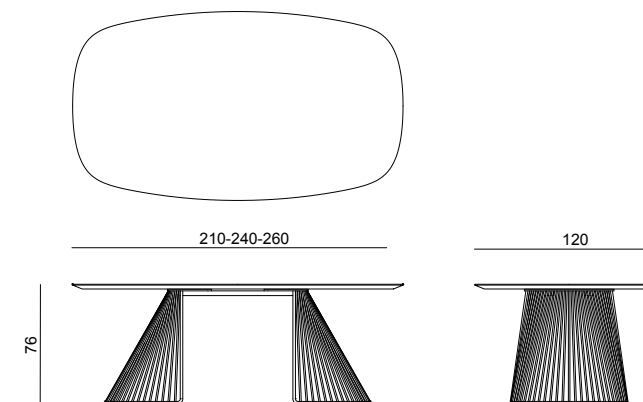

08 LUIGI FILIPPO

Marta Laudani e Marco Romanelli

Piano in medium density con bordo rastremato (riduzione perimetrale dello spessore), gambe sagomate e crociera inferiore di controvento in faggio. Il tutto laccato opaco.

Disponibile anche nelle versioni:
Piano in medium density, in abbinamento alla struttura in frassino. Il tutto laccato bianco o nero.

Piano e struttura in essenza di frassino nei colori semitrasparenti.

Piano in cristallo trasparente o extra-chiaro, in abbinamento alla struttura in frassino. Il tutto laccato bianco, nero e nei colori semitrasparenti.

Top in medium density with tapered edge (perimeter thickness reduction), shaped legs and lower winding cross in beech. Fully matt lacquered.

Also available in the following versions:
Medium density top paired with an ash frame. Full lacquer in white or black.

Top and structure in ash wood. All in semi-transparent colours.

Top in transparent or extra-clear glass, paired with an ash frame. All lacquered white, black and in semi-transparent colours.

COLORI / COLOURS

Vernici opache e lucide
Matt varnish and lacquer

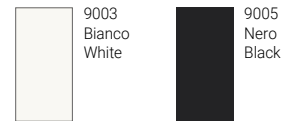

Vernici colorate trasparenti
Stain colours

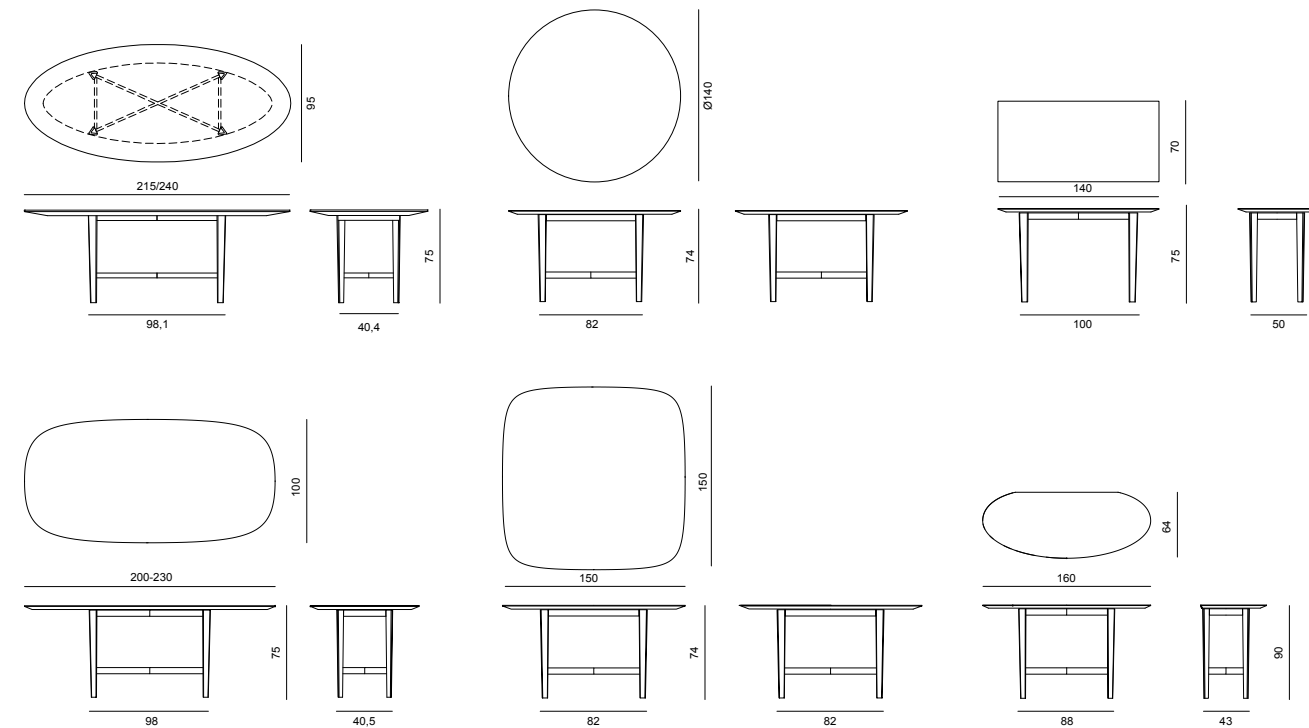

09 LAYER

Franco Poli

Tavolo iconico con piano in cristallo trasparente o extra-chiaro, in abbinamento alla struttura di strati di MDF accoppiati e laccati in colore bianco opaco. Misura unica 240x116 cm

Iconic table with a transparent or extra-clear glass top, paired with a matt white lacquered frame in laminated MDF. One size: 240x116 cm

COLORI STRUTTURA / FRAME COLOURS

Vernici opache
Matt varnish

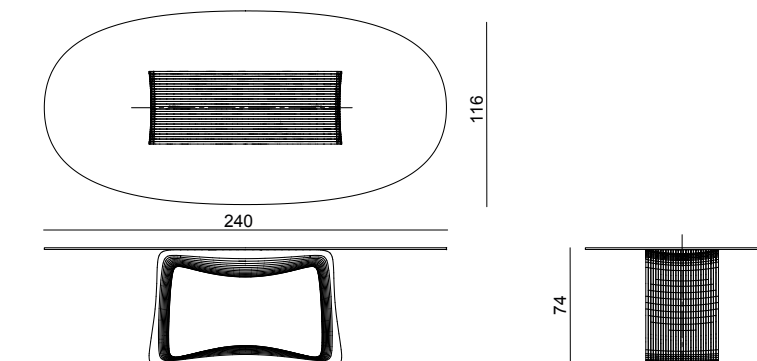
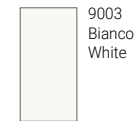

10 MEDIOLANUM

Studio Ideazione

Tavolini con piano in medium density laccato coprente nei colori bianco, nero e colorato, in abbinamento alla base a piantana o in tubolare di acciaio color acciaio cromato o verniciatura nero opaco goffrato.

Dimensioni del piano 70x70 cm, 80x80 cm, diametro 70 e diametro 80 cm. Spessore 19 mm.

Piantana a base quadrata 40 x40 cm con sezione della colonna 5 x 5 cm

Piantana a base rotonda diametro 40 cm con sezione della colonna diametro 5 cm

Dimensioni, colori e finiture particolari su richiesta.

Small tables with medium density top in opaque lacquer in white, black and coloured, paired with a pedestal base or tubular steel base in chrome or embossed matt black lacquer.

Top dimensions 70x70 cm, 80x80 cm, diameter 70 and 80 cm. Thickness 19 mm.

Square base 40 x40 cm with 5 x 5 cm column section

Floor-standing with round base diameter 40 cm, with column section diameter 5 cm

Special dimensions, colours and finishes on request.

COLORI / COLOURS

Vernici opache e lucide
Matt varnish and lacquer

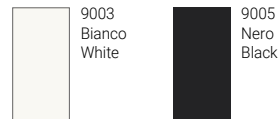

Vernici opache
Matt varnish



|| LUX

Edoardo Radice

Lampada a led dimmerabile. Corpo in alluminio profilato a freddo, microforato e verniciato color bianco o nero opaco. Fissaggio tramite magneti.

Disponibile in tre misure: 96 cm (5 W), 149 cm (10 W) e 199 cm (15 W). Può essere abbinata alla Libreria Sapiens.

Dimmable LED lamp. Body made of cold-formed, micro-perforated and matt lacquered white or black aluminium. Fixing by means of magnets.

Available in three sizes: 96 cm (5 W), 149 cm (10 W) e 199 cm (15 W). It can be matched with the Sapiens bookcase.

COLORI / COLOURS

Vernici opache
Matt varnish

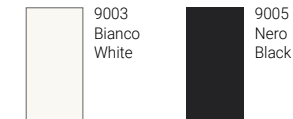

Versione per outdoor con piano in Resysta in colore Tek spazzolato, base in metallo tubolare con trattamento di cataforesi e verniciatura in nero opaco goffrato.

Outdoor version with Resysta top in brushed teak colour, tubular metal base with cataphoresis treatment and embossed matt black lacquer.

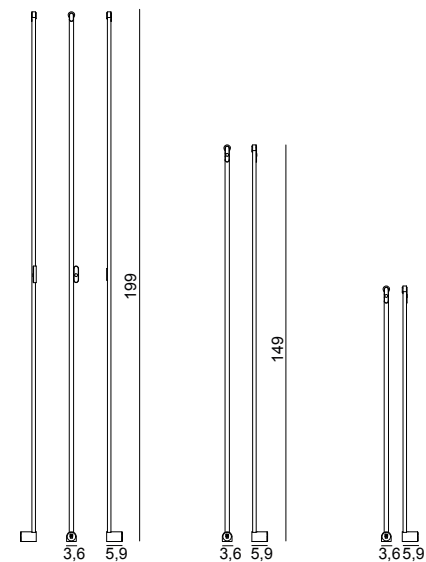
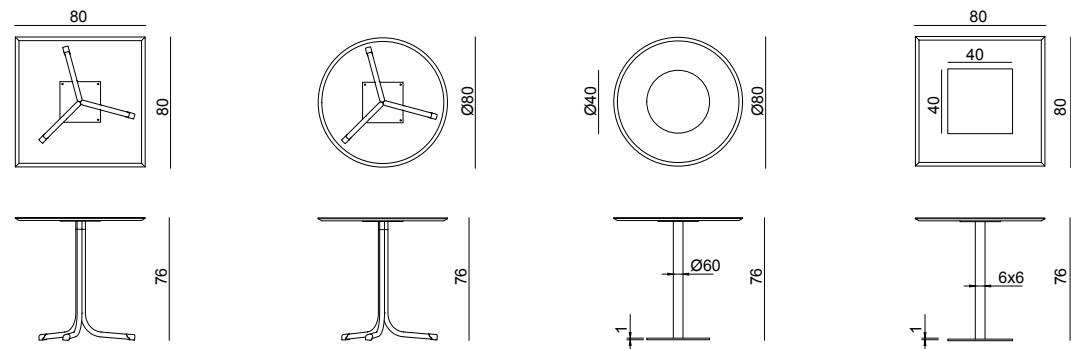
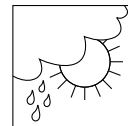

12 NEANDERTHAL

Franco Poli

Libreria in lamiera d'acciaio a forte spessore con mensole laserate da 13 cm fino a 18 cm di profondità.

Disponibile in due altezze da cinque a nove ripiani e in due versioni: self standing o fissa a parete, nei colori attuali della Sapiens: bianco, nero, rosso, corten, acciaio grezzo, grigio alluminio e grigio antracite. È prevista anche una versione a sospensione a 5 mensole.

Bookcase made of thick sheet metal with laser-cut shelves from 13 cm to 18 cm deep.

Available in two heights, from five to nine shelves, and two versions: self-standing or fixed to the wall, in the current Sapiens colours: white, black, red, weathering steel, raw steel, aluminium grey and anthracite grey. There is also a suspended version with 5 shelves.

COLORI / COLOURS

Vernici opache e lucide
Matt varnish and lacquer

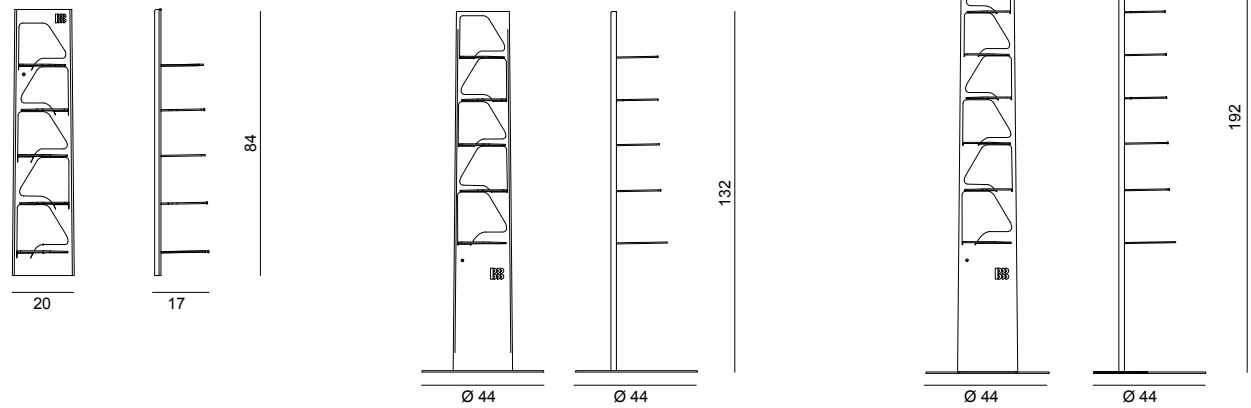
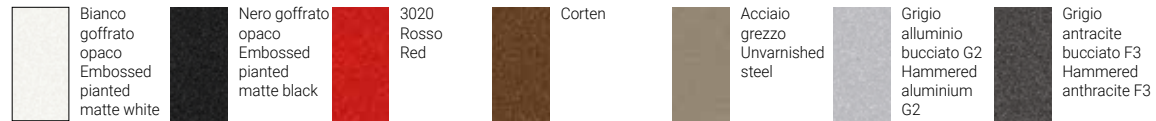

PLIXY
SEVEN
LAYER
OYSTER
CROSS
JAPAN WOOD
JAPAN STEEL
GRID
LUIGI FILIPPO
LAYER
MEDIOLANUM
LUX
NEANDERTHAL

